



**bürkert**  
FLUID CONTROL SYSTEMS



**bürkert**  
FLUID CONTROL SYSTEMS

# Types 6213 EV, 6281 EV

Solenoid valves for neutral fluid and gaseous media

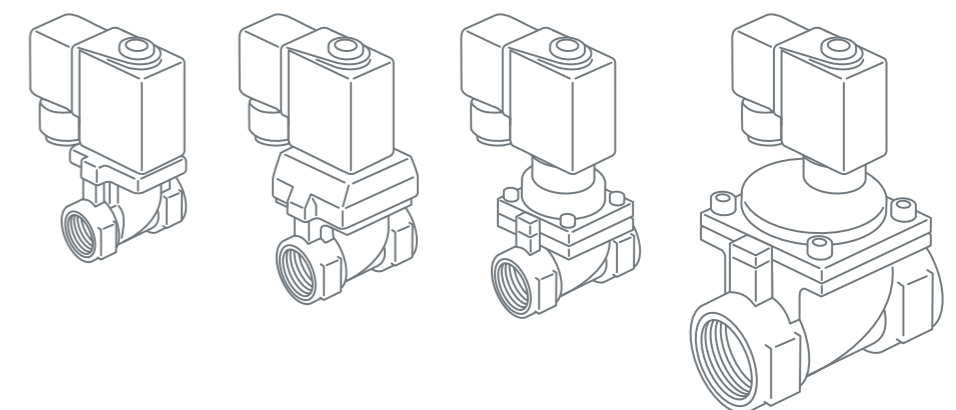

**Bürkert Fluid Control Systems**  
Christian-Bürkert-Straße 13-17  
74653 Ingelfingen  
Germany

Tel.: +49 (0) 7940/10-0  
Fax: +49 (0) 7940/10-91 204

info@burkert.com  
www.burkert.com



# Valve Family 6200 EV

## Product features and benefits

Our latest solenoid valve family 6200 EV sets new standards in actuation with proven technology and quality to fit your application.

Persuasive arguments you can count on:

### **Small and compact**

Minimized outer dimensions allow installation even under space conditions

### **Permeable**

The flow optimized internal design of the valve guarantees you a high flow even with small process connections

### **Flexible**

The modular construction and breadth of material variety offer a customized solution for your application

### **Easy**

The clear and consistent program makes fast and easy valve selection possible

# Solenoid Valves 6200 EV Program Overview

The solenoid valves from the new product series 6200 from Bürkert are suitable for a broad spectrum of standard applications with fluidic and gaseous media. Typical applications are water, compressed air and vacuum such as found in car washes, drinking water treatment plants, swimming pool technologies, heating and refrigerating systems. With the suitable selection of materials, solutions for aggressive media are also available.

6213 EV brass



6281 EV brass

## Versions in brass or stainless steel

The type 6213 EV and 6281 EV solenoid valves are available in brass and stainless steel as standard. However, particularly for applications with stringent requirements for chemical resistance, stainless steel is often the only solution. The 6281 EV valve can also be used in potentially explosive areas.

6213 EV stainless steel



6281 EV stainless steel

# Product features and technical data type 6213 EV

Servo-assisted 2/2-way Solenoid valve with diaphragm for liquids and gaseous media starting from 0 bar differential pressure

- Opens without differential pressure
- Short installation length
- Water hammer free and low audible noise
- High flow rate for small process connections
- Sealed and bolted coil system



Technical data	
Body material	Brass Stainless steel 1.4408 (316)
Process connections	Brass G1/4 ... G2 Stainless steel G3/8 ... G2
Seal and diaphragm material	EPDM, NBR, FKM
Pressure range	0 ... 10 bar
Media (depending on materials selected)	water, neutral fluids, hydraulic oils, per-solutions, oils with additives
Protection	IP65
Voltages	24VDC, 24 VAC, 230VAC
Electrical connection	Plug according to EN 175301-803 Form A

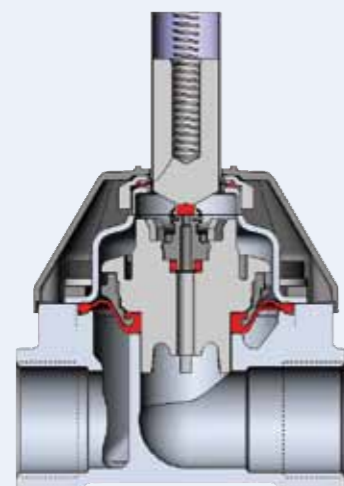

Diaphragm valve – Spring coupled

Like other servo assisted valves, these spring coupled valves take advantage of the fluid's pressure to operate. The addition of a direct soft mechanical coupling between the main diaphragm or piston and the plunger of the pilot armature means that there is some extra assistance.

# Product features and technical data type 6281 EV

Servo-assisted 2/2-way Solenoid valve with diaphragm for liquids and gaseous media starting from 0,2 bar differential pressure

- Water hammer free and low noise
- Short installation length
- High flow rate for small process connections
- Sealed and bolted coil system
- Low power consumption
- Universal and flexible with options
  - Manual override
  - Version: normally opened (NO)
  - Explosion proof version



Technical data	
Body material	Brass Stainless steel 1.4408 (316)
Process connections	Brass G3/4 ... G2 Stainless steel G1/2 ... G2
Seal and diaphragm material	EPDM, NBR, FKM
Pressure range	0,2 ... 16 bar
Media (depending on materials selected)	Water, neutral fluids, liquid bases, compressed air, per-solutions
Protection	IP65
Voltages	24VDC, 24 VAC, 230VAC
Electrical connection	Plug according to EN 175301-803 Form A

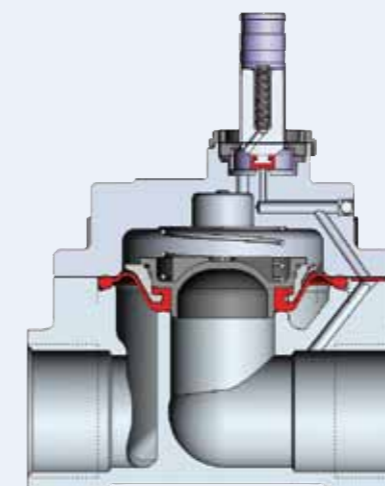

Servo assisted valve – plunger piloted

This operating method uses a direct acting plunger valve as the pilot valve and the main valve seal is a flexible diaphragm.

These valves require a minimum pressure differential to exist between the inlet port and the outlet port.