

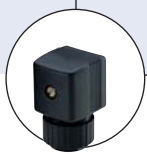

Type 5282 can be combined with...



Type 2508
Cable plug



Type 1078
Timer unit



Type 2511
ASI cable plug



Type 0142
Solenoid valve

2/2-way Solenoid Valve with servo diaphragm

- Pivoted armature pilot drive with manual override
- Magnetic drive completely isolated from fluid by diaphragm
- Circuit function can be changed (NC or NO)
- Adjustable switching times (anti-waterhammer)
- Tolerates slightly contaminated and aggressive fluids

Type 5282 is a pilot actuated solenoid valve using a servo diaphragm. A separating diaphragm totally isolates the magnetic drive and the fluid. The valve is designed for universal use with gases and liquids. Type 5282 is the only true full stainless steel and full brass valve.

Manual override feature is a standard. Switching times (opening and closing) are individually adjustable.

Circuit function A

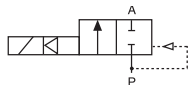

2/2-way valve, NC

Circuit function B

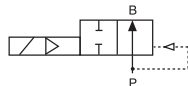

2/2-way valve, NO

changeover of circuit function by turning of pilot valve (10bar version only)

Technical data	
Orifice	DN 13 - 65 mm
Body material	Brass acc. to DIN EN 50930-6, stainless steel 1.4581
Threaded port	Stainless steel 1.4541
Flange	
Coil encapsulation material	Epoxy
Coil insulation class	H
Seal material	NBR, EPDM, FKM
Medium	Neutral fluid, such as compressed air, water, hydraulic oil
NBR	Oil and fat-free fluid, e.g. alkaline solutions, hot water
EPDM	Hot air, peracetic acid, hot oil
FKM	
Medium temperature	
NBR	0 to +80 °C
EPDM	-30 to +90 °C
FKM	0 to +90 °C
Ambient temperature	Max. +55 °C
Voltage tolerance	±10 %
Duty cycle	100% duty cycle
Electrical connection	Cable plug acc. DIN EN 175301-803 Form A (previously DIN 43650)
Protection class	IP 65 with cable plug
Installation	as required, preferably connected upright

A differential pressure of 0.5 bar is required to open the full orifice. The response times can be changed by turning the restrictor screws (in the body cover).

Technical data, cont.

Orifice [mm]	Power consumption			Response times 1)	
	Inrush AC [VA]	Hold AC [VA/W]	DC cold/warm [W]	Opening [s]	Closing [s]
13-65	24	14/8	11/8	0.1-0.8	1.0-4.0

1) Measured at valve outlet at 6 bar and +20°C. Opening: pressure build-up 0 to 90%, Closing: pressure relief 100 to 10%

Ordering chart for valves (other versions on request)

Brass body, threaded port, with manual override, without cable plug

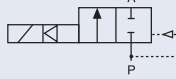
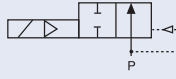
Circuit function	Port connection	Orifice [mm]	Kv value water [m³/h]	Nominal pressure [bar]	Weight [kg]	Item no. per voltage/frequency [V/Hz]			
						024/DC	024/50-60	230/50-60	
A  2/2-way valve, NC or by turning the pilot drive through 180°	Brass body, threaded port, seal material NBR								
	G 1/2	13.0	4.0	0.2 – 10	0.95	134 430	134 431	134 433	
	G 3/4	20.0	6.5	0.2 – 10	1.40	134 434	134 435	134 437	
	G 1	25.0	10.0	0.2 – 10	1.85	134 438	134 439	134 441	
	G 1 1/4	32.0	20.0	0.2 – 10	2.60	134 442	134 443	134 445	
	G 1 1/2	40.0	20.0	0.2 – 10	3.05	134 446	134 447	134 449	
	G 2	50.0	40.0	0.2 – 10	5.15	134 450	134 451	134 453	
	G 2 1/2	65.0	40.0	0.2 – 10	5.90	134 454	134 455	134 457	
	Brass body, threaded port, seal material EPDM								
	G 1/2	13.0	4.0	0.2 – 10	0.95	134 458	134 459	134 461	
G 3/4	20.0	6.5	0.2 – 10	1.40	134 462	134 463	134 465		
G 1	25.0	10.0	0.2 – 10	1.85	134 466	134 467	134 469		
G 1 1/4	32.0	20.0	0.2 – 10	2.60	134 470	134 471	134 473		
G 1 1/2	40.0	20.0	0.2 – 10	3.05	134 474	134 475	134 477		
G 2	50.0	40.0	0.2 – 10	5.15	134 478	134 479	134 481		
G 2 1/2	65.0	40.0	0.2 – 10	5.90	134 482	134 483	134 485		
B  2/2-way valve, NO	Brass body, threaded port, seal material FKM								
	G 1/2	13.0	4.0	0.2 – 10	0.95	134 486	134 487	134 489	
	G 3/4	20.0	6.5	0.2 – 10	1.40	134 490	134 491	134 493	
	G 1	25.0	10.0	0.2 – 10	1.85	134 494	134 495	134 497	
	G 1 1/4	32.0	20.0	0.2 – 10	2.60	134 498	134 499	134 501	
	G 1 1/2	40.0	20.0	0.2 – 10	3.05	134 502	134 503	134 505	
	G 2	50.0	40.0	0.2 – 10	5.15	134 506	134 507	134 509	
	G 2 1/2	65.0	40.0	0.2 – 10	5.90	134 510	134 511	134 513	

Please note that the cable plug has to be ordered separately, see Ordering chart for accessory on separate datasheet, Type 2508.

Delivered as circuit function A

Change to the circuit function B by turning the pilot drive through 180° (only for 10 bar version)

Mounting instructions:

Arrangement of the pilot control

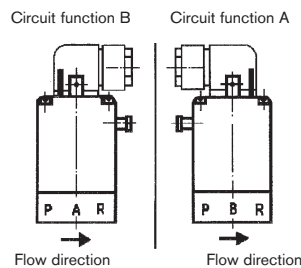

Ordering chart for valves (other versions on request), cont.

Stainless steel body, threaded port or flange, with manual override, without cable plug

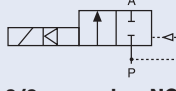
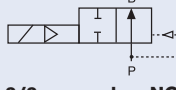
Circuit function	Port connection	Orifice [mm]	Kv value water [m ³ /h]	Nominal pressure [bar]	Weight [kg]	Item no. per voltage/frequency [V/Hz]			
						024/DC	024/50-60	230/50-60	
A  2/2-way valve, NC or by turning the pilot drive through 180° B  2/2-way valve, NO	Stainless steel, threaded port, seal material NBR								
	G 3/4	20.0	5.0	0.2 – 10	1.40	137 142	137 143	137 145	
	G 1	25.0	10.0	0.2 – 10	1.80	137 146	137 147	137 149	
	G 1 1/4	32.0	20.0	0.2 – 10	2.25	137 150	137 151	137 153	
	G 1 1/2	40.0	20.0	0.2 – 10	2.70	137 154	137 155	137 157	
	G 2	50.0	40.0	0.2 – 10	4.80	137 158	137 159	137 161	
	Stainless steel, threaded port, seal material FKM								
	G 1/2	13.0	4.0	0.2 – 10	0.91	220 291	220 292	220 294	
	G 3/4	20.0	5.0	0.2 – 10	1.40	134 518	134 519	134 521	
	G 1	25.0	10.0	0.2 – 10	1.80	134 522	134 523	134 525	
	G 1 1/4	32.0	20.0	0.2 – 10	2.25	134 526	134 527	134 529	
	G 1 1/2	40.0	20.0	0.2 – 10	2.70	134 530	134 531	134 533	
	G 2	50.0	40.0	0.2 – 10	4.80	134 534	134 535	134 537	
	Stainless steel, threaded port, seal material EPDM								
G 1/2	13.0	4.0	0.2 – 10	0.91	220 297	220 298	220 300		
G 3/4	20.0	5.0	0.2 – 10	1.40	141 714		145 709		
G 1	25.0	10.0	0.2 – 10	1.80	141 078		146 160		
G 1 1/4	32.0	20.0	0.2 – 10	2.25	438 559		147 803		
G 1 1/2	40.0	20.0	0.2 – 10	2.70	141 667		139 823		
G 2	50.0	40.0	0.2 – 10	4.80	141 075		146 530		
Stainless steel flange acc. DIN 2501 with FKM									
Flange	25.0	10.0	0.2 – 10	3.65	134 554	134 555	134 557		
Flange	32.0	20.0	0.2 – 10	6.45	134 558	134 559	134 561		
Flange	40.0	20.0	0.2 – 10	7.05	134 562	134 563	134 565		
Flange	50.0	40.0	0.2 – 10	10.5	134 566	134 567	134 569		
Stainless steel flange acc. DIN 2501 with EPDM									
Flange	25.0	10.0	0.2 – 10	3.65	134 570	134 571	134 573		
Flange	32.0	20.0	0.2 – 10	6.45	134 574	134 575	134 577		
Flange	40.0	20.0	0.2 – 10	7.05	134 578	134 579	134 581		
Flange	50.0	40.0	0.2 – 10	10.5	134 582	134 583	134 585		

¹⁾ measured at +20°C, 1 bar pressure at valve inlet and free outlet

²⁾ Pressure values [bar]: Overpressure to the atmospheric pressure

Please note order cable plug separately, see Ordering chart for accessory datasheet type 2508

Delivered as circuit function A

Change to circuit function B by turning the pilot drive by 180° (only for 10 bar version)

i Further versions on request

Voltage
110/50-60

Approvals
UL, UR, CSA, Hazardous Locations Expl. proof, EEx m/ed, CGA/AGA

Additional
With optical or electrical feedback

Pressure
Pressure range up to 16 bar

Materials

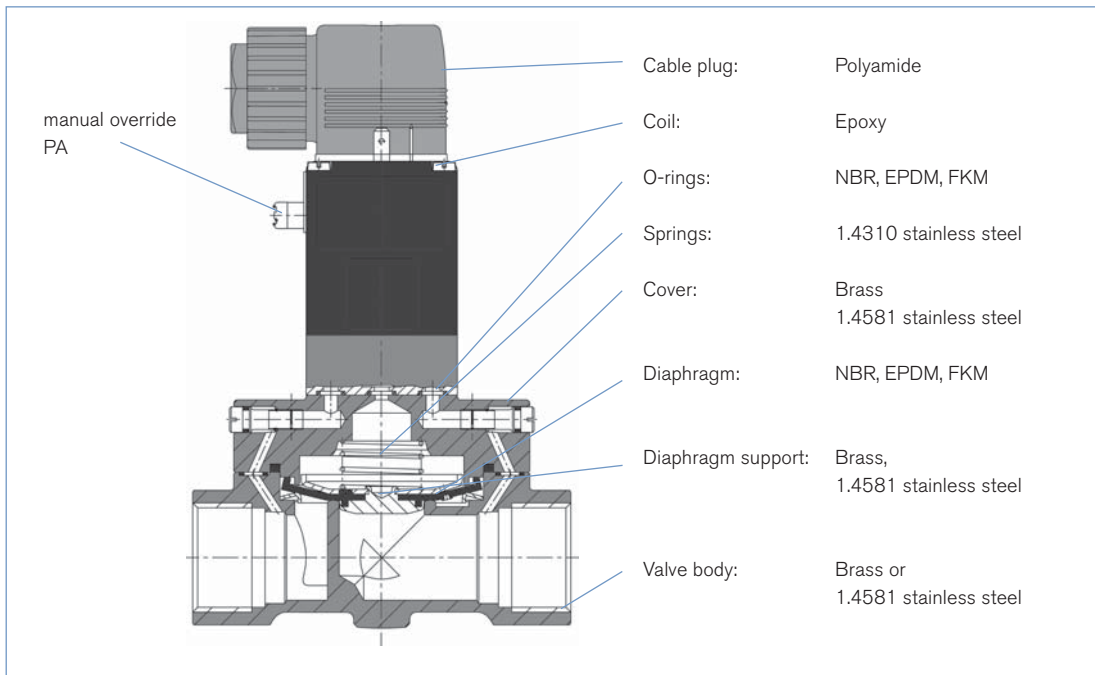

Ordering chart accessory

Cable plug acc. to DIN EN 175301-803 Form A (previously DIN 43650)

Cable plug includes flat seal and fixing screw. For other cable plug versions acc. to DIN EN 175301-803 Form A (previously DIN 43650), see data-sheet Type 2508.

Circuitry	Voltage	Item no.
None (standard)	0-250 V	008 376
with LED	12-24 V	008 360
with LED and varistor	12-24 V	008 367
with rectifier, LED and varistor	12-24 V	008 363
with LED	200-240 V	008 362
with LED and varistor	200-240 V	008 369
further versions see datasheet Type 2508		

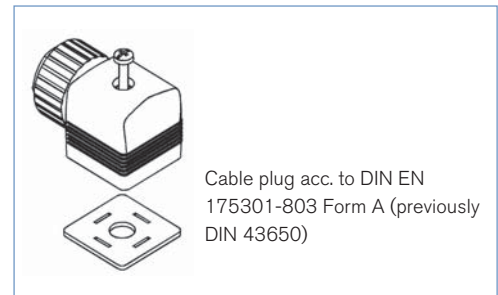

Dimensions [mm]

Threaded port

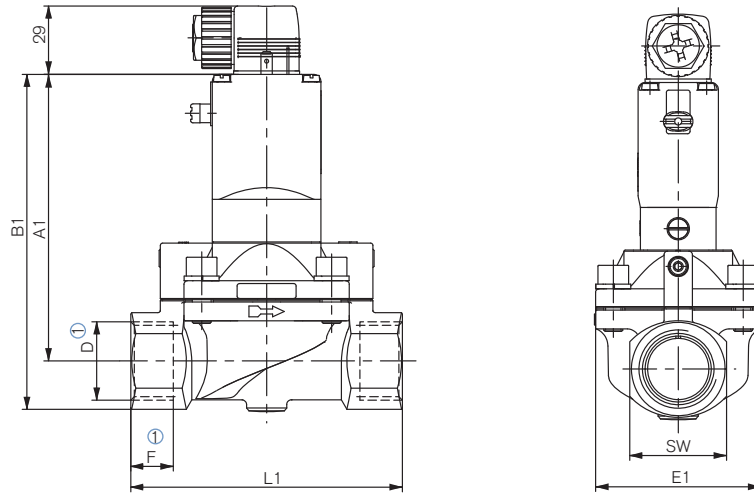

① For port connection G thread F1 and G1 applies,
port connection NPT thread F2 and G2,
port connection Rc thread F3 and G3.

② only as VA- thread port version

③ only as MS- thread port version

Threaded port											
DN	D1	A1	B1	F1	D2	F2	D3	F3	E1	L1	SW
③ 13		109.0	123.0				Rc 3/8	10.1	40	65	27
③ 13	G 1/2	109.0	123.0	14	NPT 1/2	13.7	Rc 1/2	13.2	40	65	27
② 13	G 1/2	108.0	124.0	14	NPT 1/2	13.7	Rc 1/2	13.2	40	65	32
② 13	G 3/4	108.0	124.0	16	NPT 3/4	14.0	Rc 3/4	14.5	40	65	32
② 20	G 1/2	115.0	131.0	14	NPT 1/2	13.7	Rc 1/2	13.2	60	100	32
20	G 3/4	115.0	131.0	16	NPT 3/4	14.0	Rc 3/4	14.5	60	100	32
25	G 1	121.5	142.0	18	NPT 1	16.8	Rc 1	16.8	70	115	41
32	G 1 1/4	122.0	147.0	20	NPT 1 1/4	17.3	Rc 1 1/4	19.1	85	126	50
40	G 1 1/2	126.0	156.0	22	NPT 1 1/2	17.3	Rc 1 1/2	19.1	85	126	60
50	G 2	142.5	177.5	24	NPT 2	17.6	Rc 2	23.4	115	164	70
65	G 2 1/2	142.5	185.0	27	NPT 2 1/2	23.6	Rc		115	180	85

Dimensions [mm], continued

Flange port

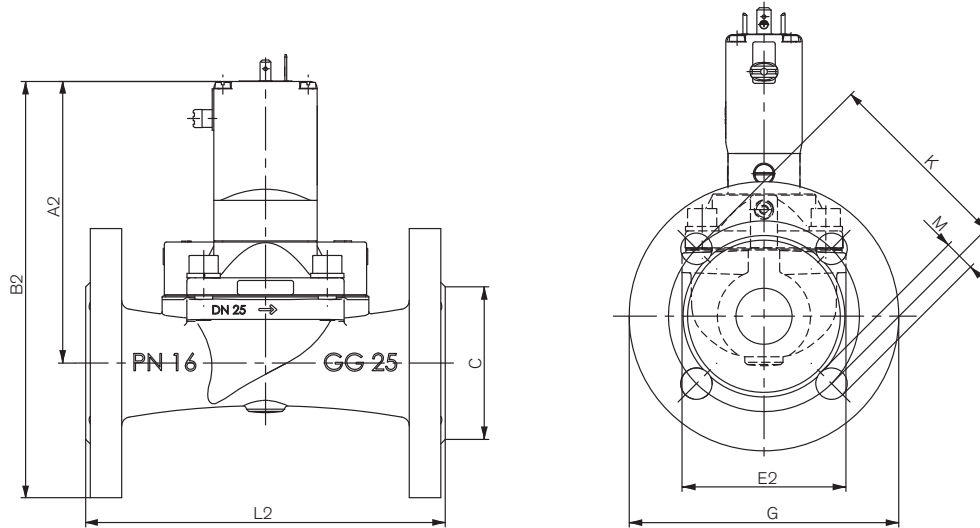

Flange port in VA and GG

DN	A2	B2	C	E2	G	L2	M	K
25	125.5	185.5	68	73	120	160	14	85
32	122.0	192.0	78	85	140	180	18	100
40	126.0	201.0	88	85	150	200	18	110
50	142.5	225.0	102	115	165	230	18	125

To find your nearest Bürkert facility, click on the orange box →

www.burkert.com
In case of special application conditions,
please consult for advice.Subject to alteration.
© Christian Bürkert GmbH & Co. KG

1112/5_EU-en_00891712